

Инструкция по установке Toyota Land Cruiser 200 (2007-)



+7 (495) 669-38-36

Арт.: F.5713.001
F.5713.003



1500 kg





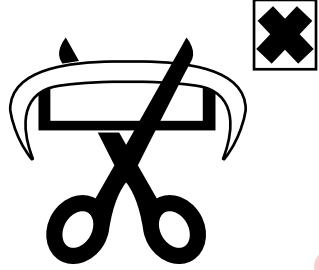

75 kg

D = 10,1 kN



D (kN) =

			
MAX kg	x	MAX kg	
<hr style="width: 100%;"/>			
			
MAX kg	+	MAX kg	

x 0,00981

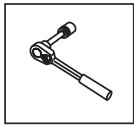

Вкрутить/выкрутить используя инструмент

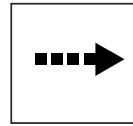

Движение

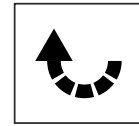

Поворот



Вкрутить/выкрутить не затягивая

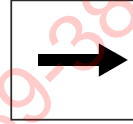

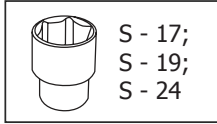
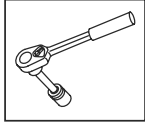

Расположение

Используемый инструмент:

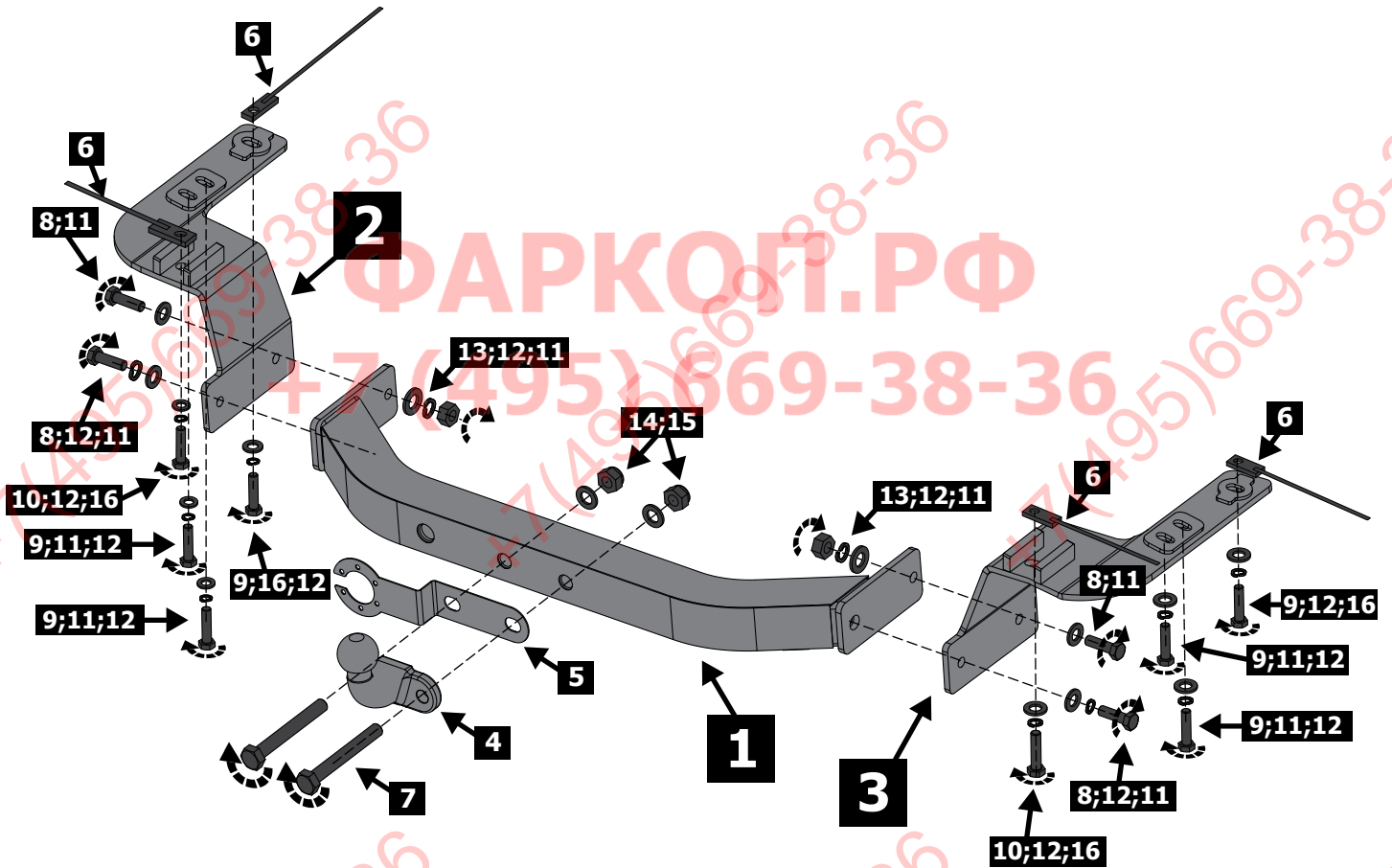

S - 17;
S - 19;
S - 24

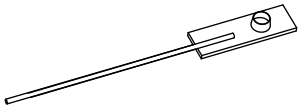

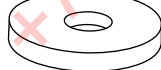
1	x1	Балка	
2	x1	Кронштейн левый	
3	x1	Кронштейн правый	
4	x1	Крюк	
5	x1	Подрозетник	
6	x4	M12	
7	x2	M16x110	
8	x4	M12x1,25x40	
9	x6	M12x1,25x50	
10	x2	M12x1,25x70	
11	x10	∅ 12	
12	x12	∅ 12	
13	x2	M12x1,25	
14	x2	∅ 16	
15	x2	M16	
16	x4	∅ 12	

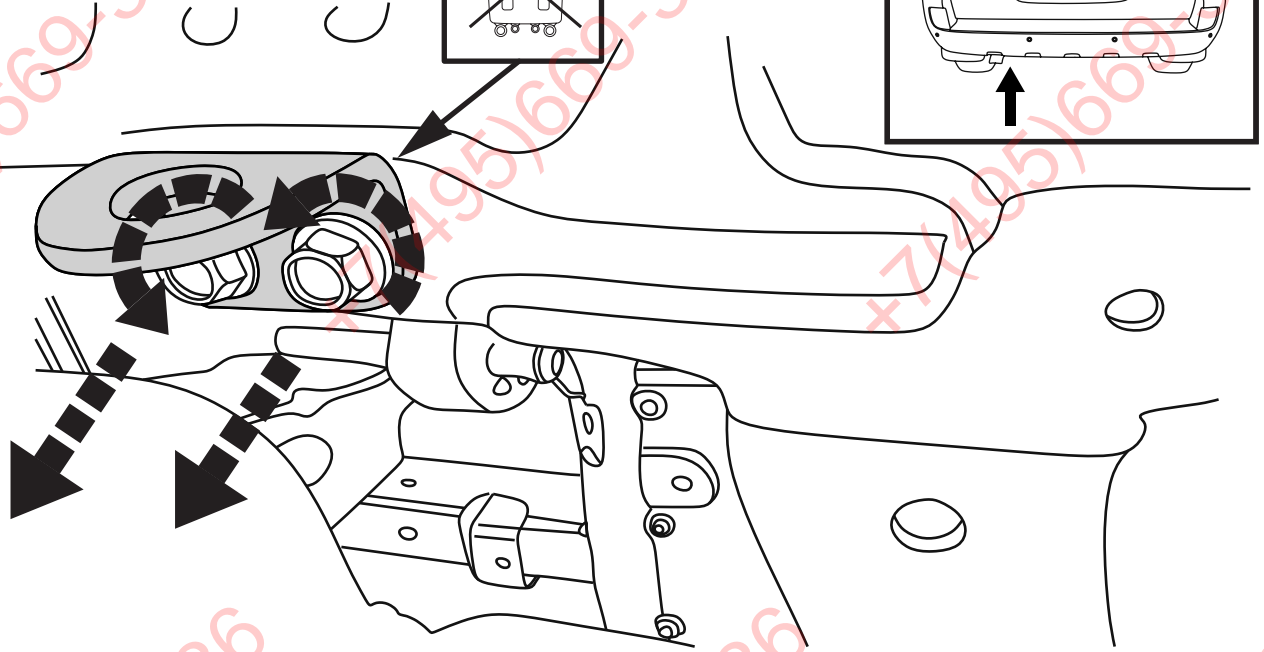
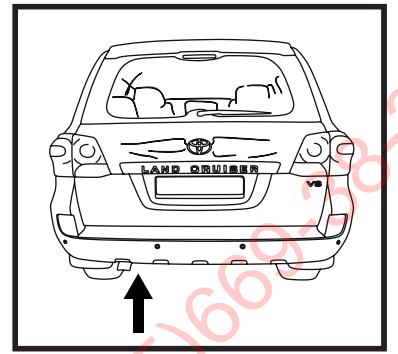
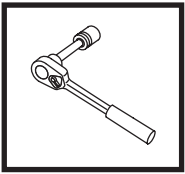

1

ФАРКОГ.РФ

+7 (495) 669-38-36

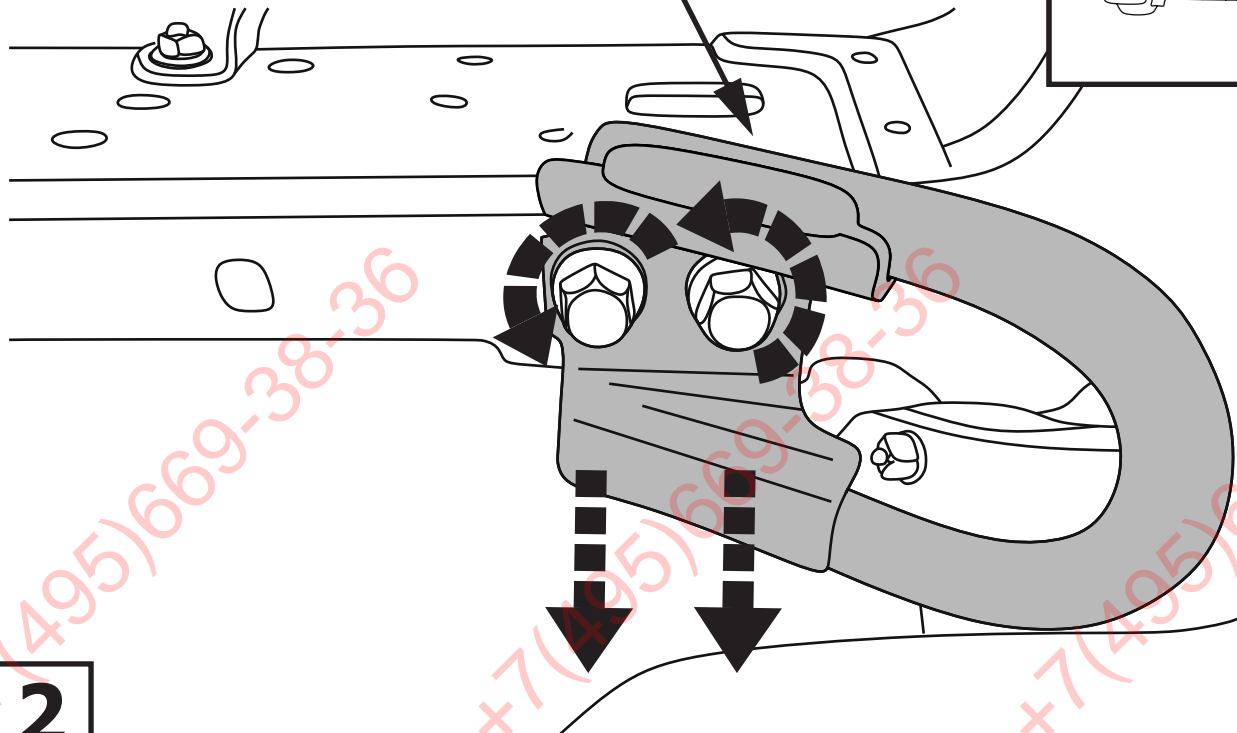
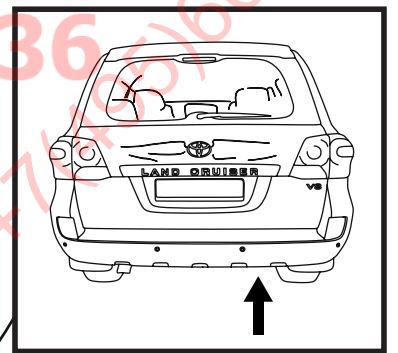
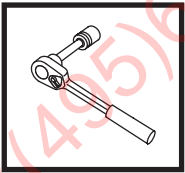

2

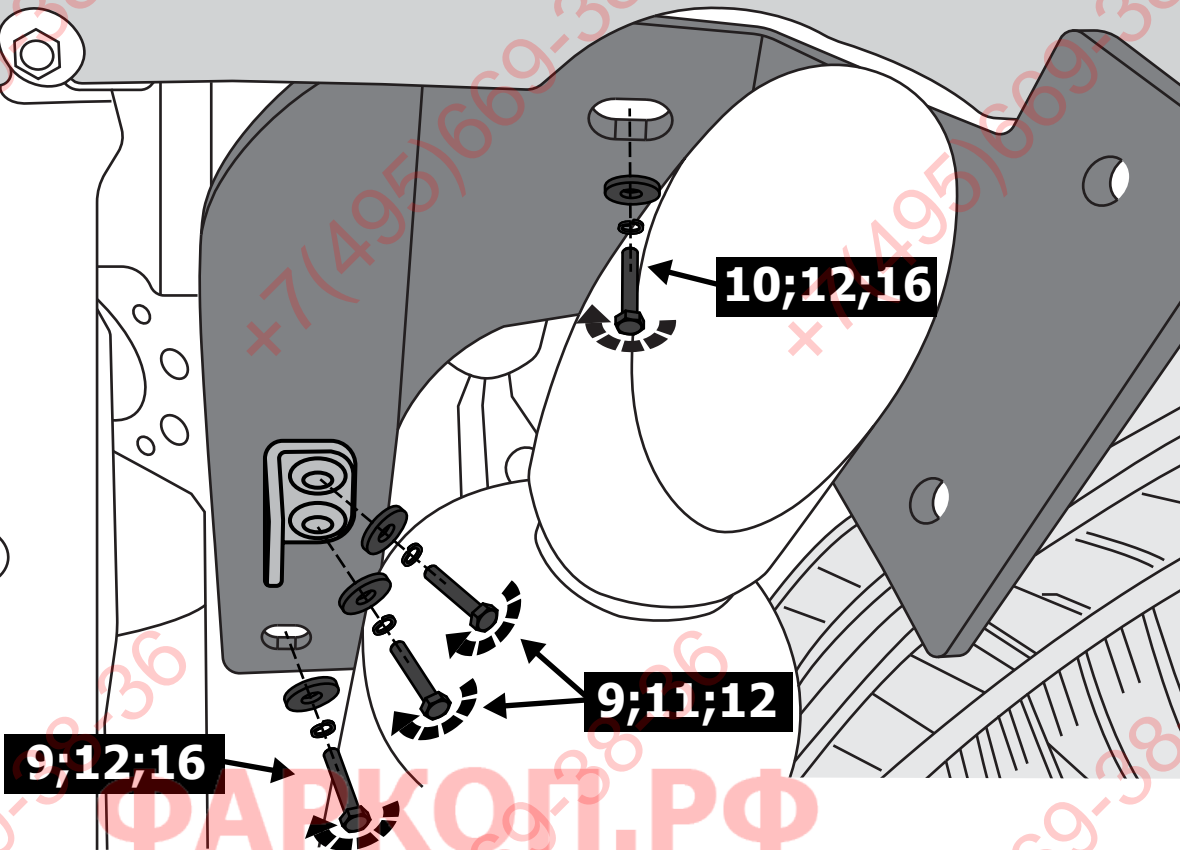

5

9;12;16

9;11;12

10;12;16

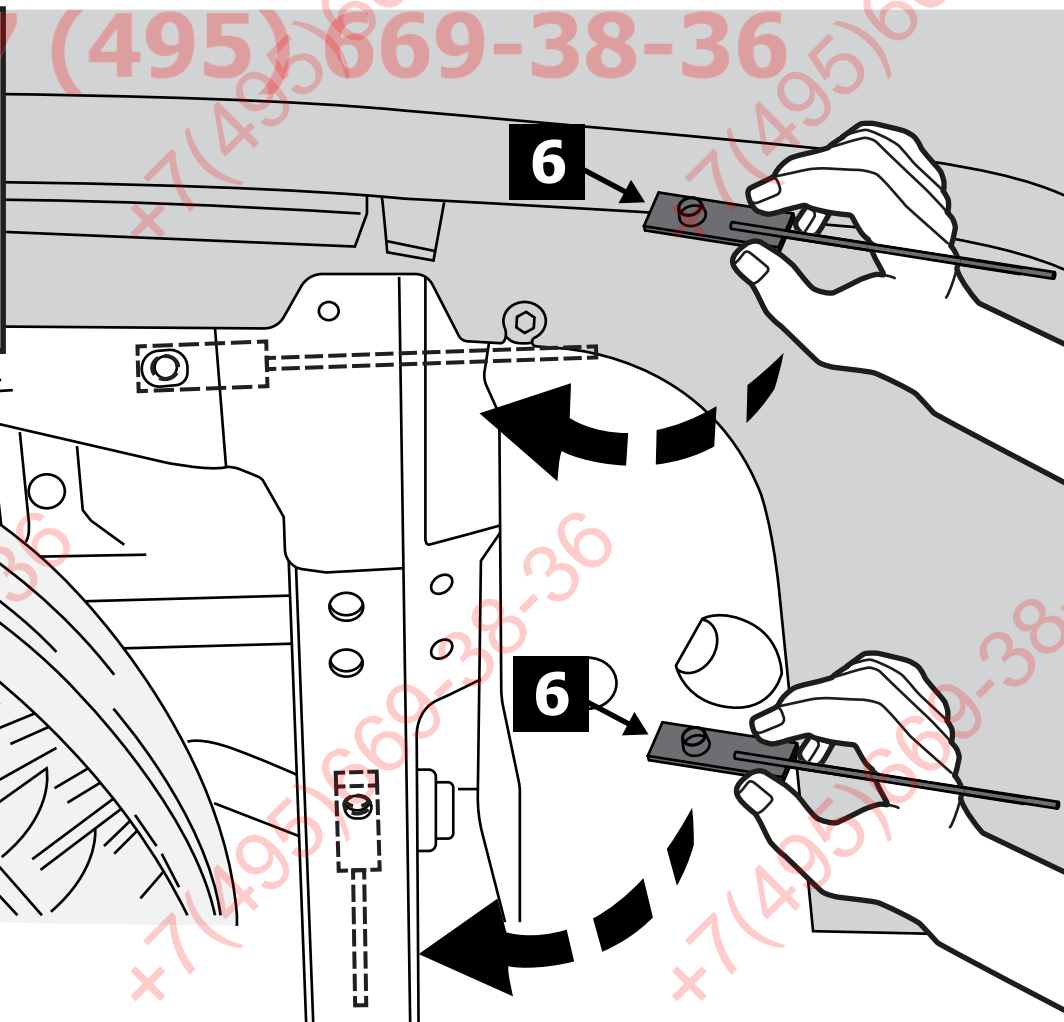
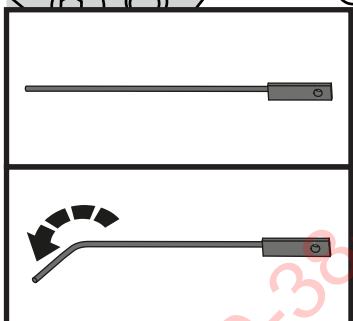
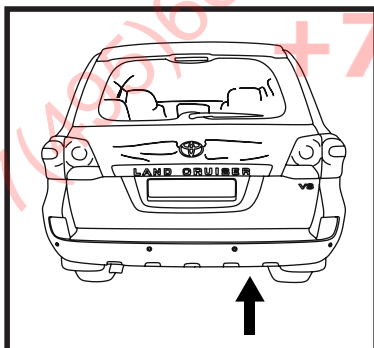

6

6

6

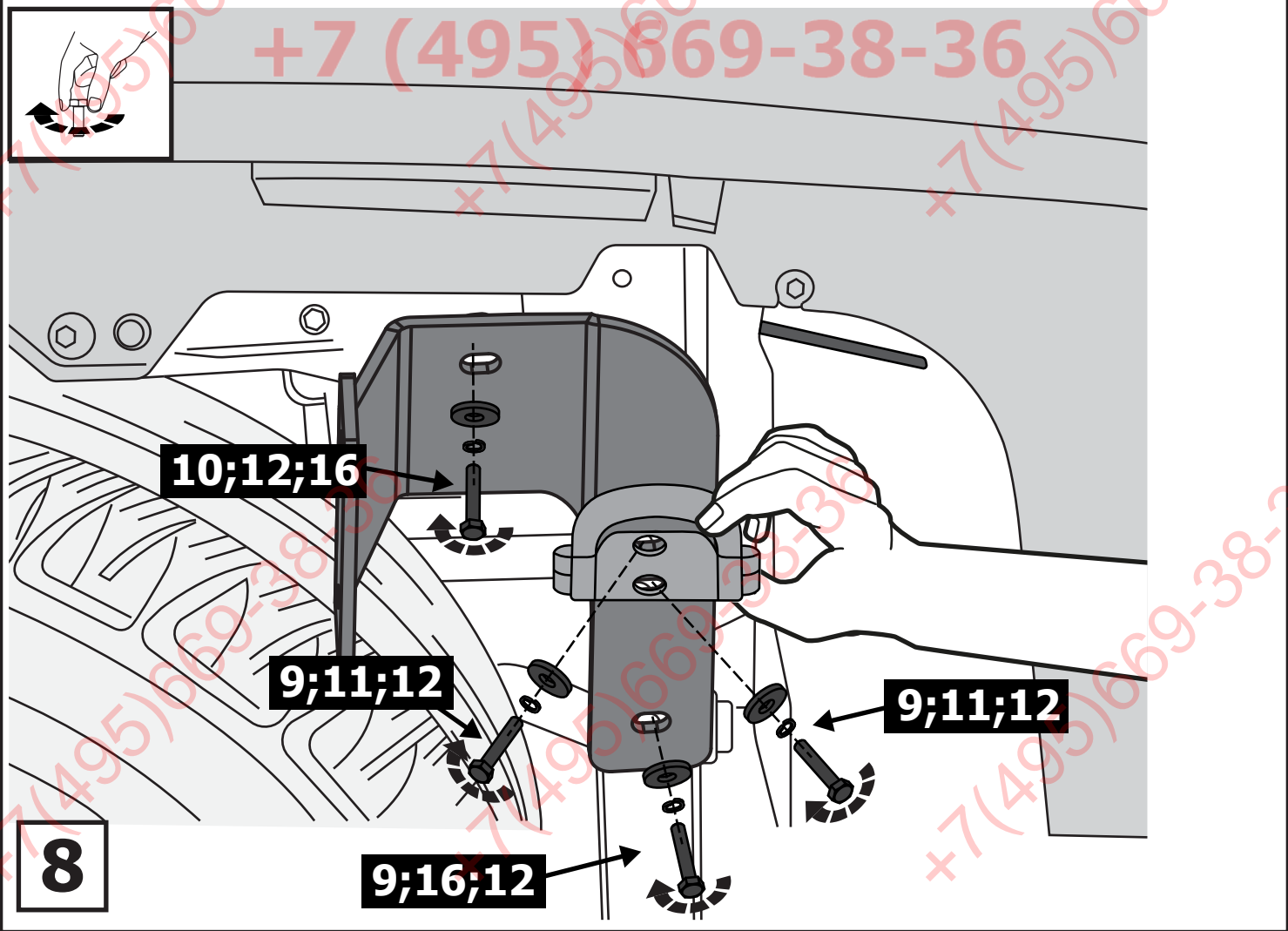
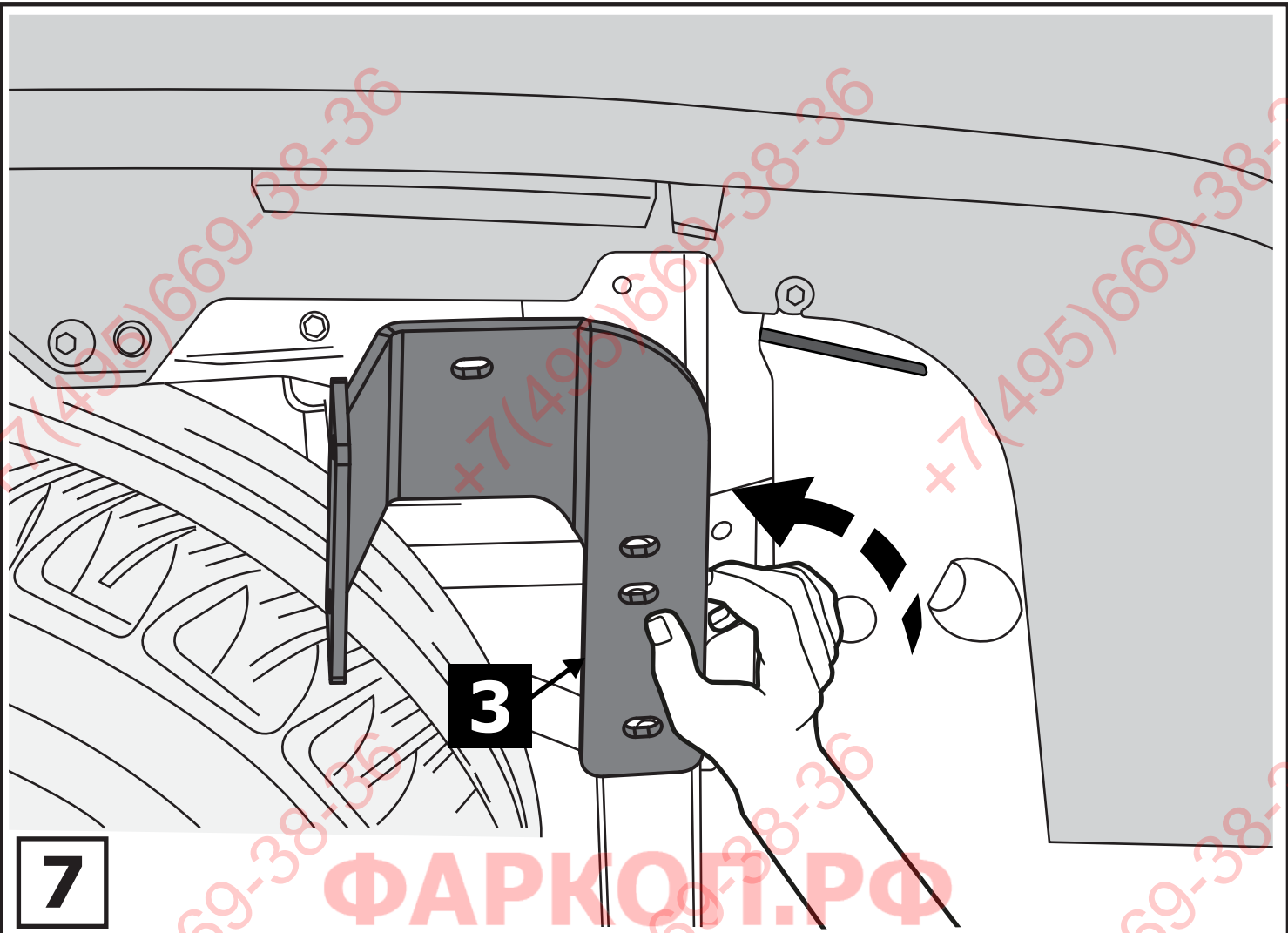

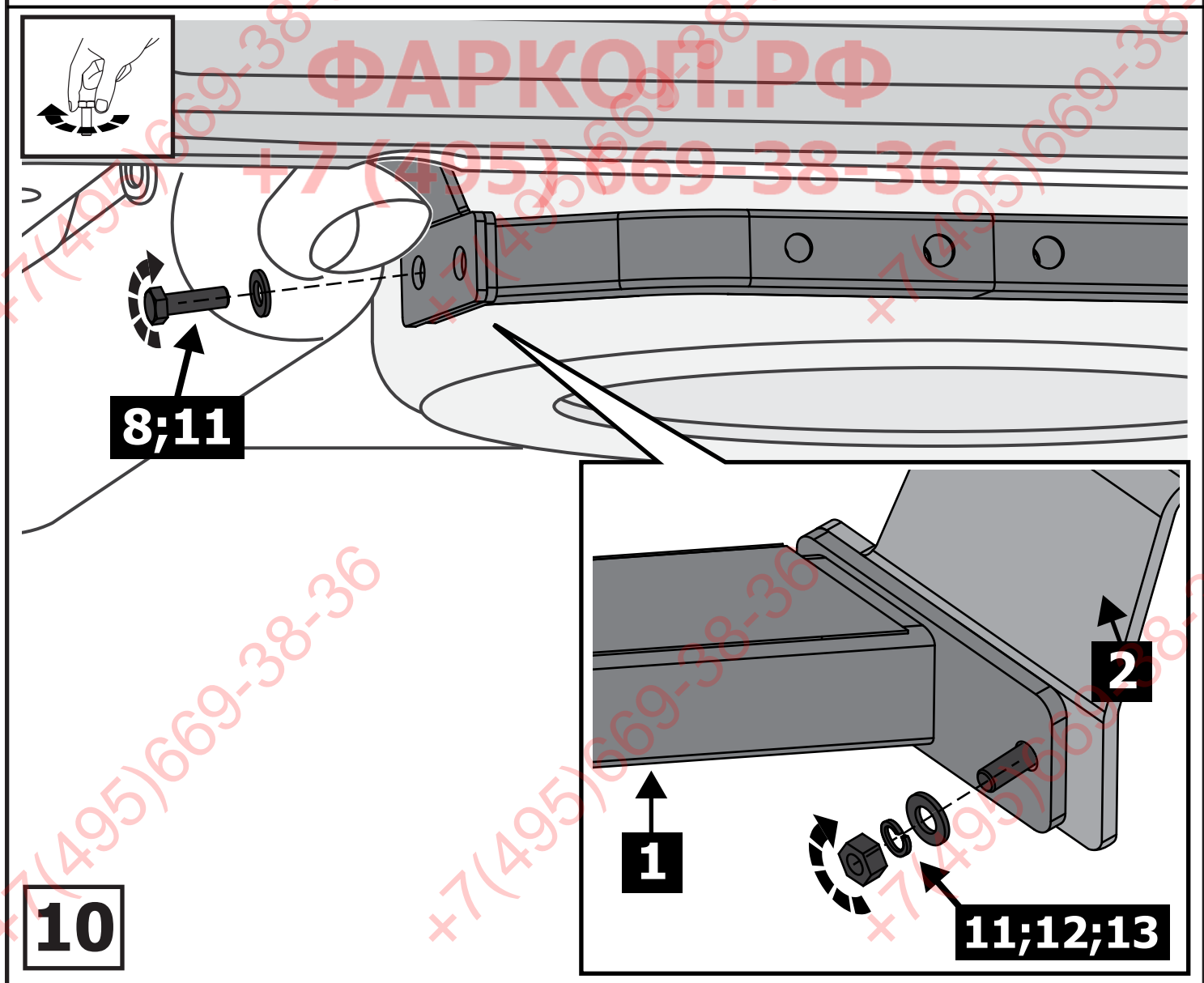
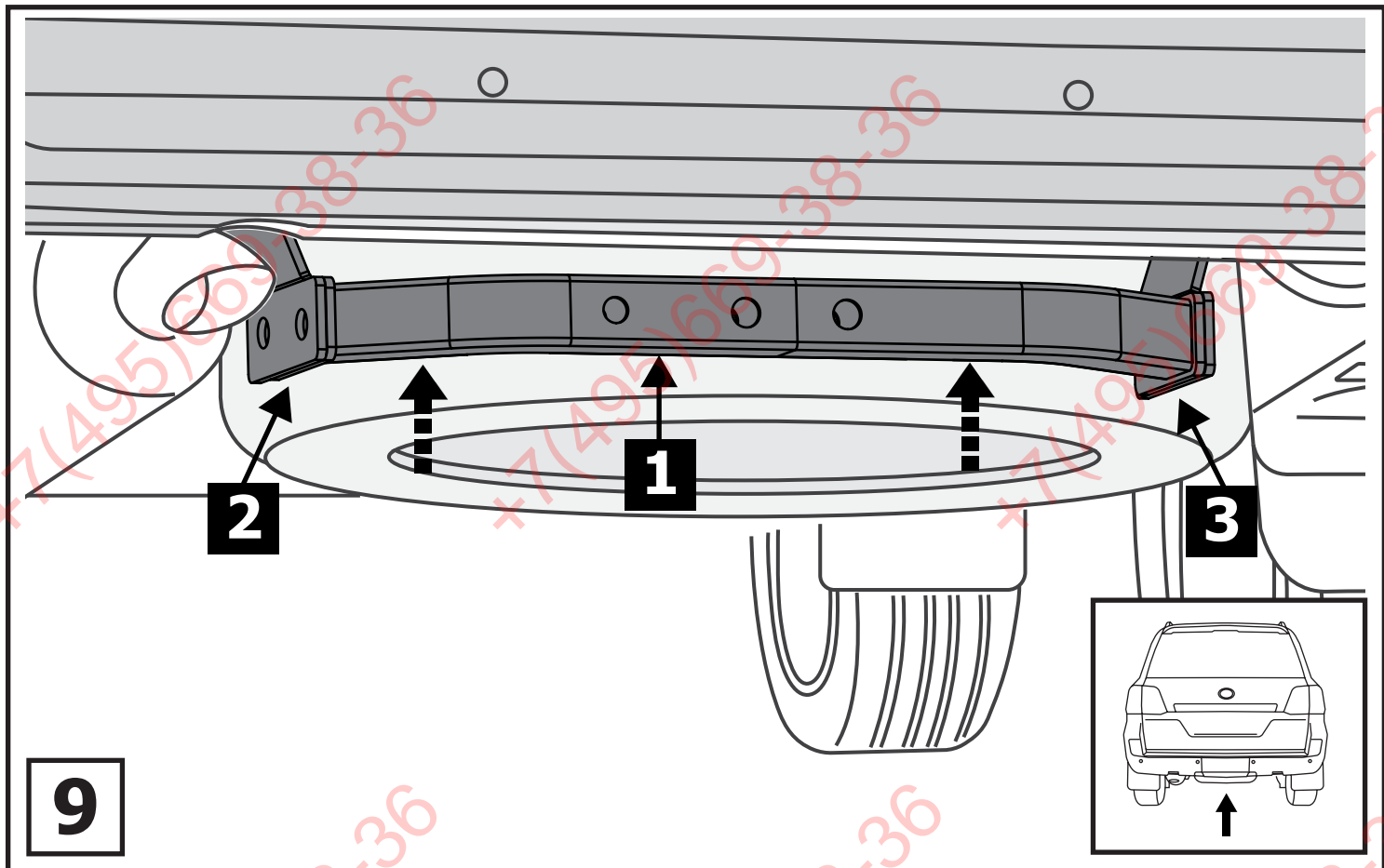

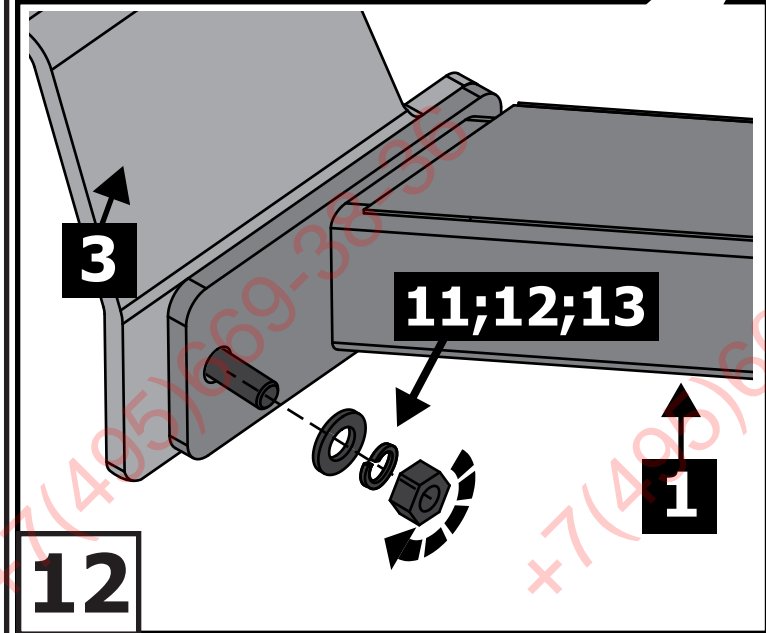
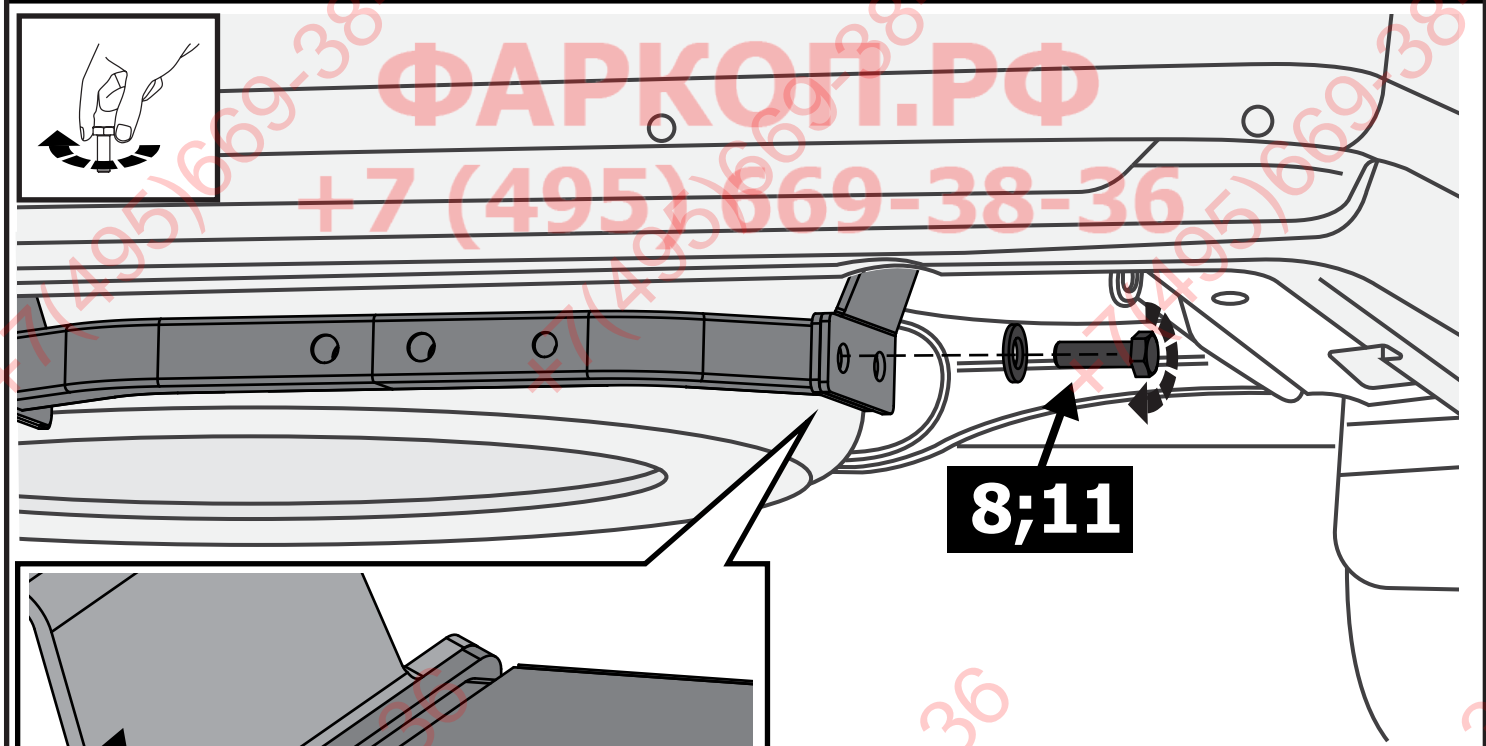
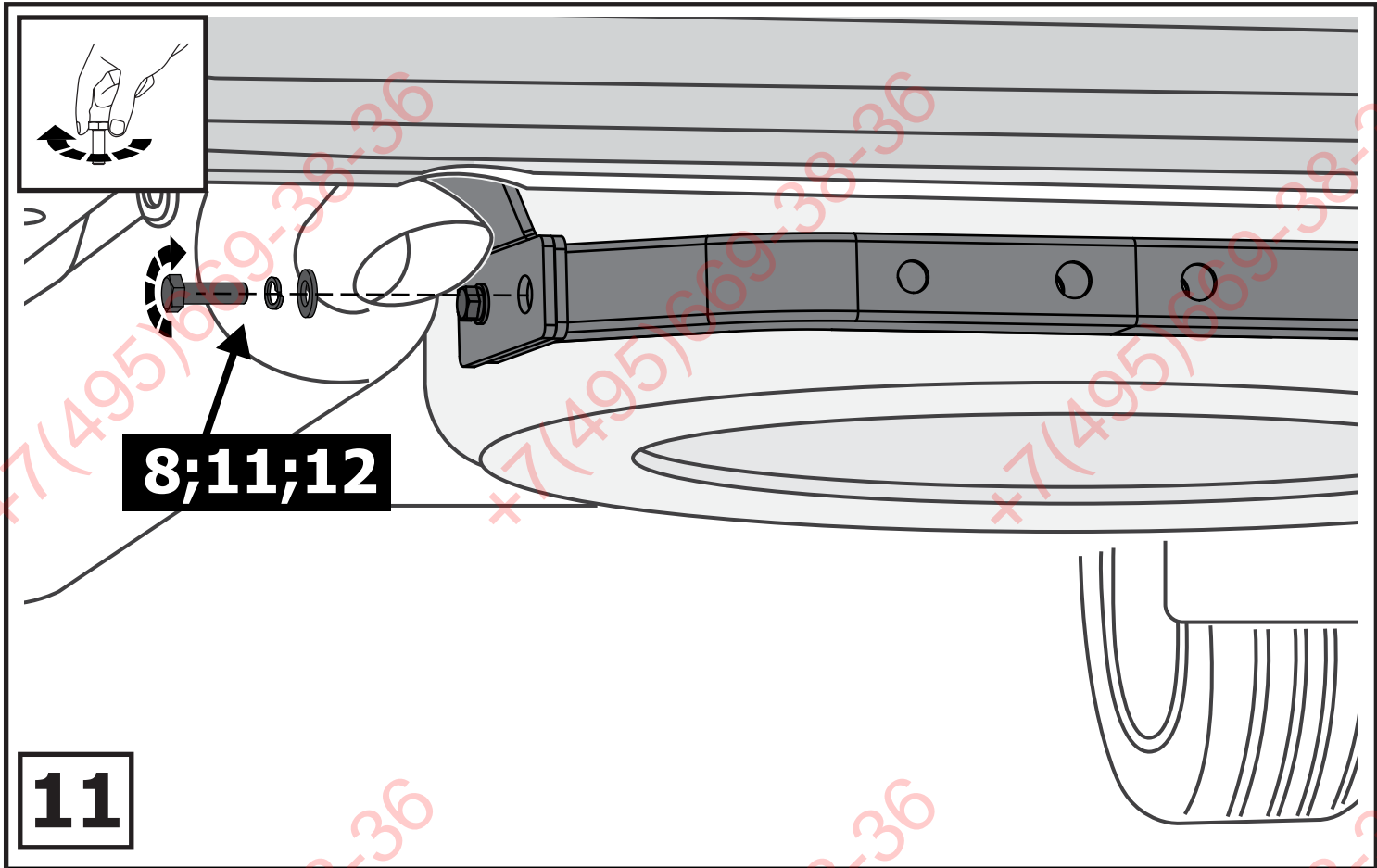

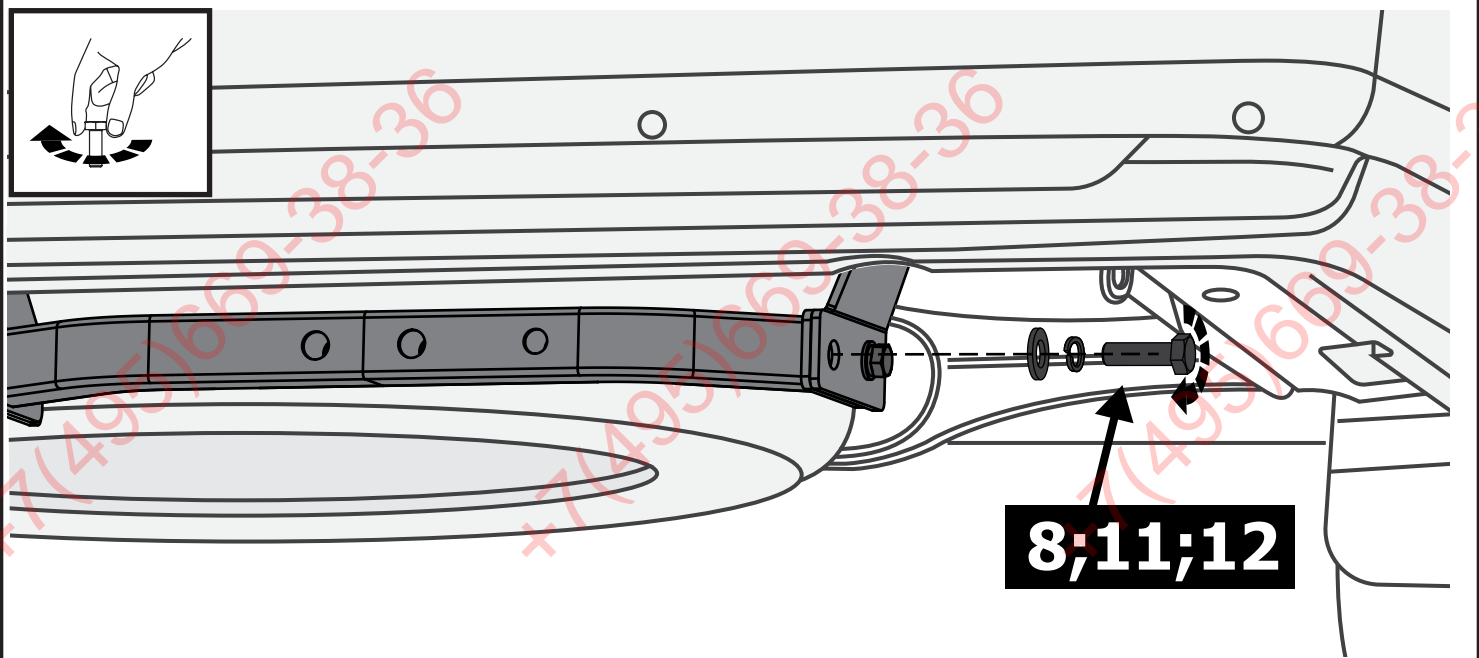

13

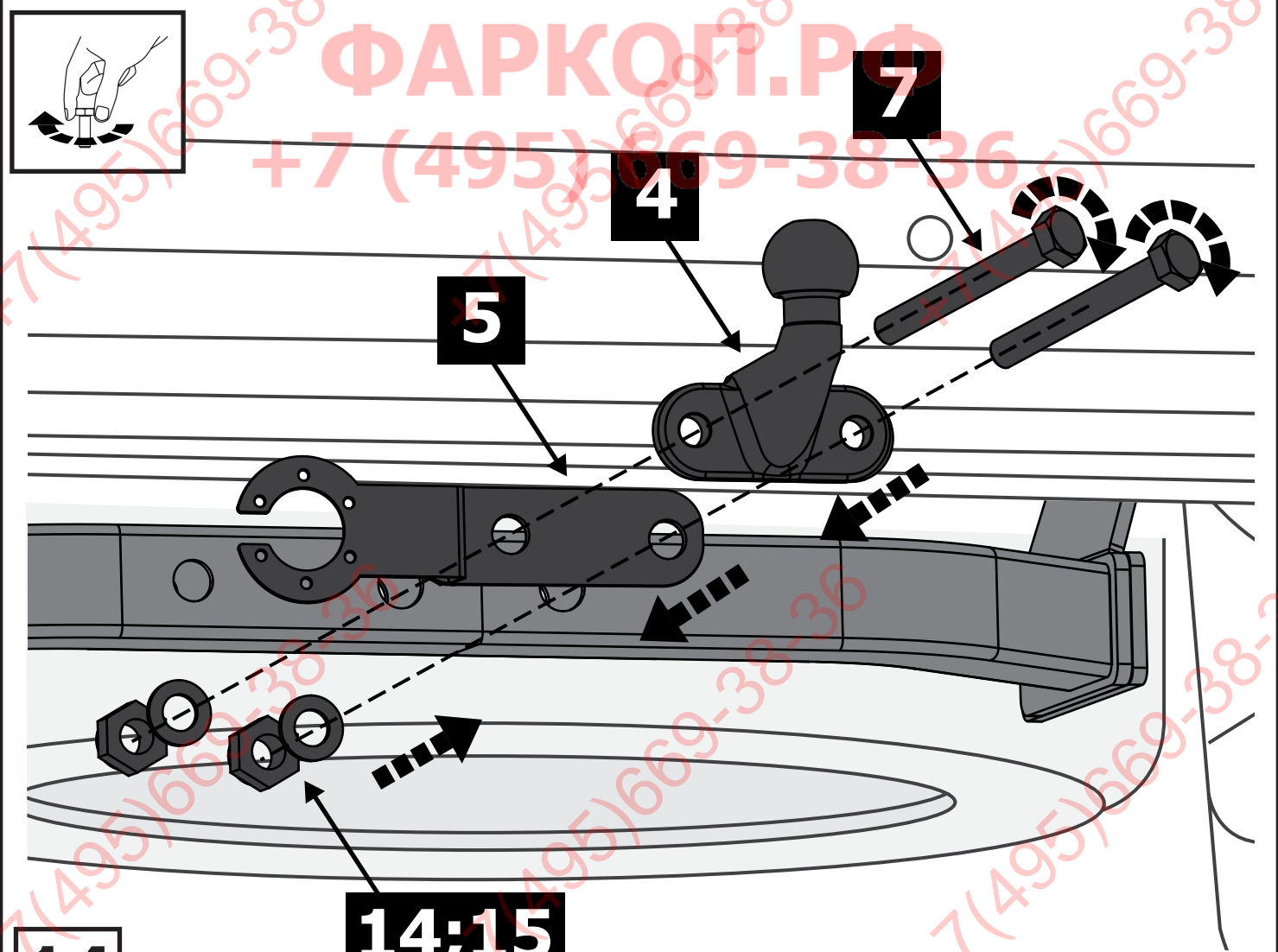

14

15

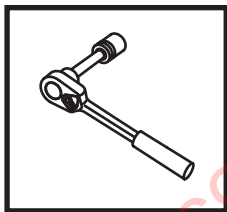
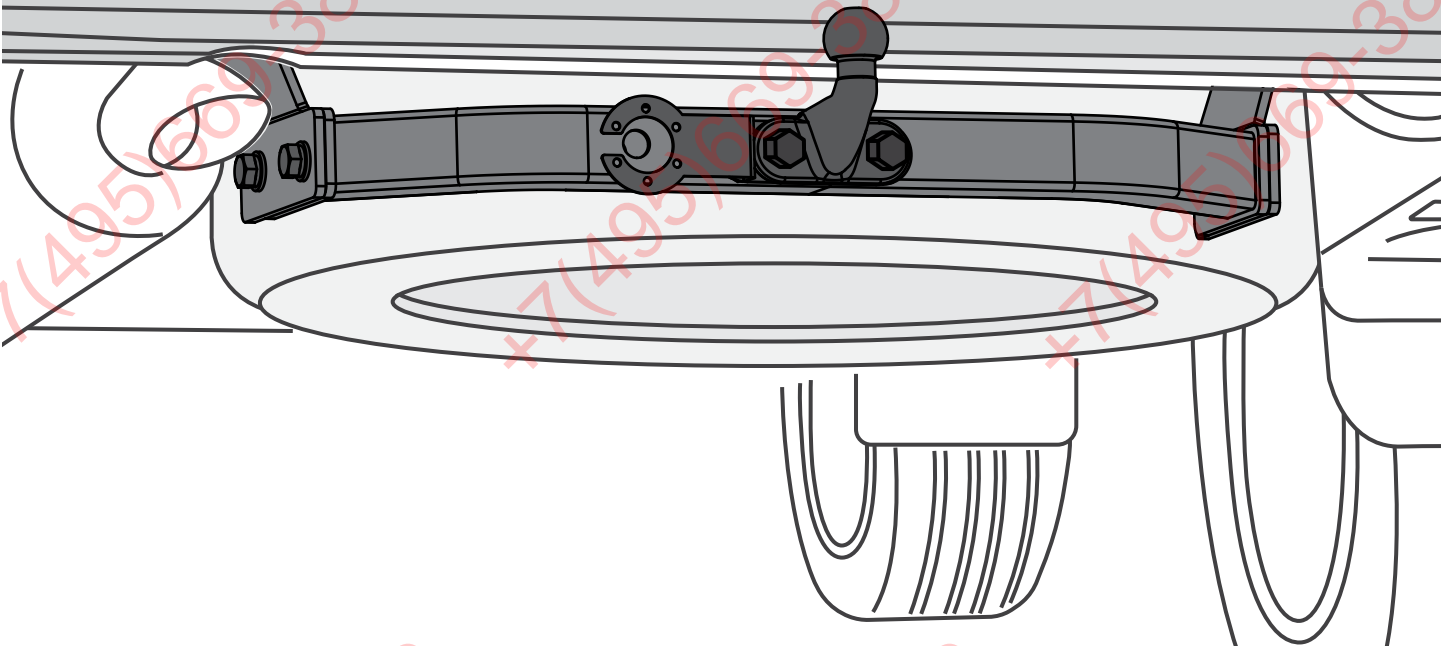

Затянуть все резьбовые соединения

M12 = 81 Nm M16 = 157 Nm

+7 (495) 669-38-36